

Duo-Aire

® DPC
Conveyor
Pizza Oven Hood

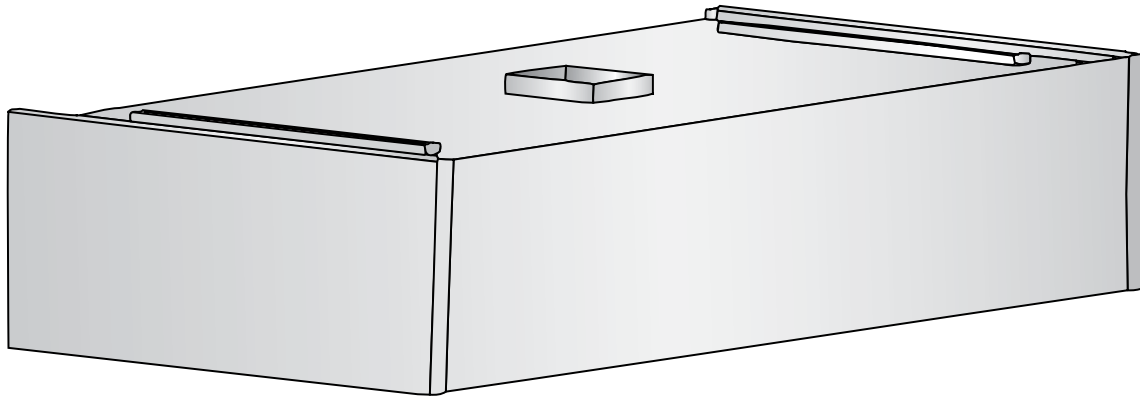

Model DPC

A single shell exhaust only cap style canopy specifically designed to ventilate conveyor pizza ovens. Canopy to be constructed of stainless steel front and ends, aluminized steel top, back and bottom. Canopy is spot welded with UL Listed grease filters. Hanging brackets provided to hang hood 1/2" above oven. Hood ends shall be removable for service and cleaning of oven. A clean out door shall be located in bottom center of canopy. Round or square duct provided as required

STANDARD FEATURES

- Stainless Steel Construction Where Visible
- Custom Designed Per Oven Model
- UL Listed Aluminum Grease Filters
- Exhaust Collar Installed
- Removable End Panels
- Removable Grease Trough & Cup
- Hanging Brackets

OPTIONS

- All Stainless Steel Construction
- All Welded Construction
- UL Listed Stainless Steel Grease Filters

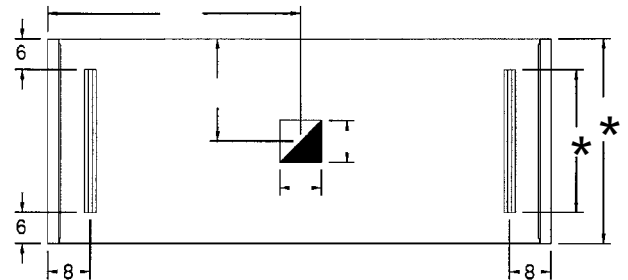

Plan View

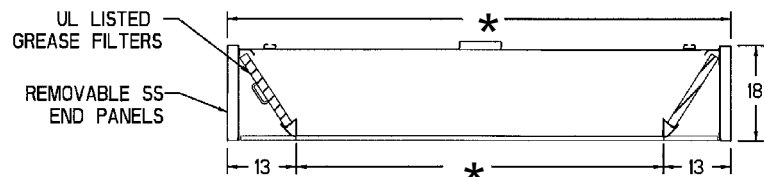

Elevation

(See reverse side for larger drawings)

* OVEN MODEL NUMBER OR SIZE
REQUIRED BEFORE PRODUCTION

BUILT IN
ACCORDANCE
WITH NFPA 96



DPC Series - Conveyor Pizza Oven Hood

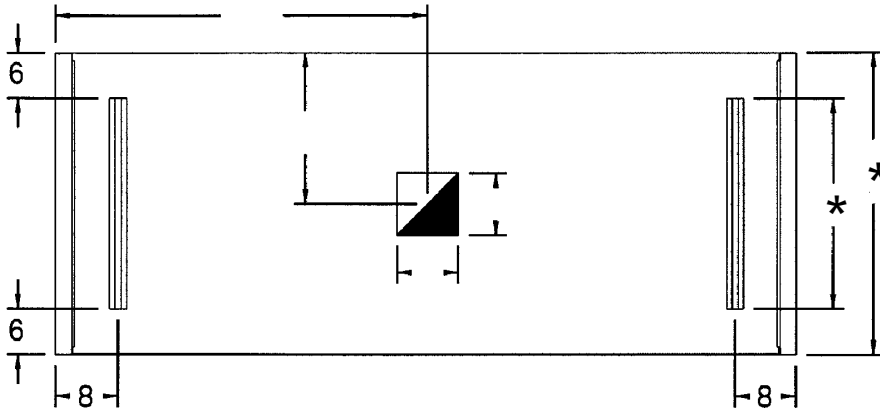

Plan View

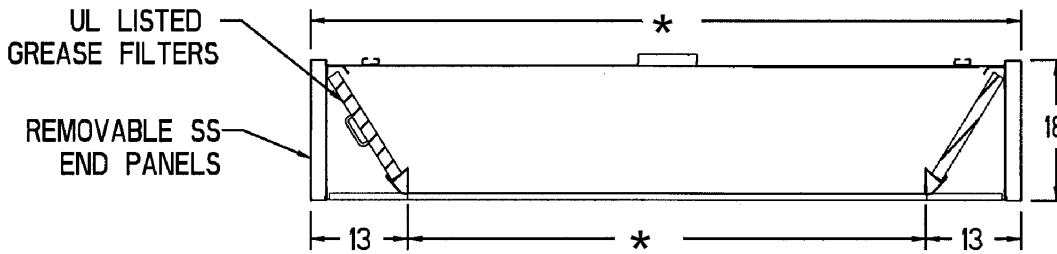

Elevation

* OVEN MODEL NUMBER OR SIZE REQUIRED BEFORE PRODUCTION
 NOTE: Hood to be installed 1" above oven

EXHAUST RATE REQUIREMENTS

Electric Oven	CONVEYOR PIZZA OVEN			
	Single Deck	Double Deck	Triple Deck	Four Decks
CFM Exhaust	400	600	800	1000
Gas Oven				
CFM Exhaust	800	1200	1600	2000

ORDER ENTRY INFORMATION

Project:

Item:

Representative:

Model:

Length: Qty:

Width:
Height:

Exhaust CFM:

Entered by:

Date:

Drawings Req'd: Y N

List Miscellaneous Options Separately

Duo-Aire[®]

Duo-Aire reserves the right to make changes in design and specifications without prior notice.